

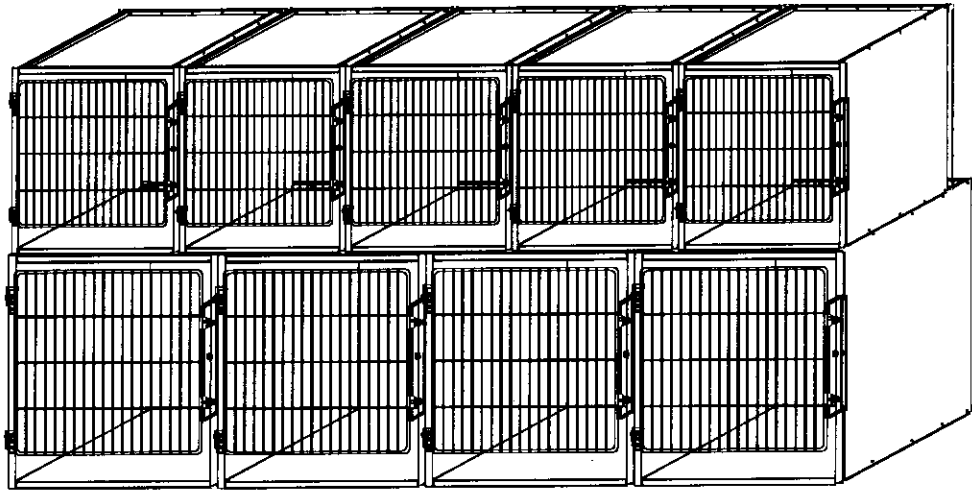

MODULAR CAGES ASSEMBLY INSTRUCTIONS



UNPACKING AND CHECKING THE CONTENTS

Unpack the contents carefully. Before assembly examine all parts for damage that may have occurred during shipping. If any damage found, immediately call your distributor or an Edemco Customer Service Representative.

BEFORE YOU START

1. This manual provides procedures for the assembly of your Edemco cage bank system. Read all instructions.
2. Take inventory of all parts (see page 4 for Parts Identification).
3. Make sure you have the tools required for assembly.

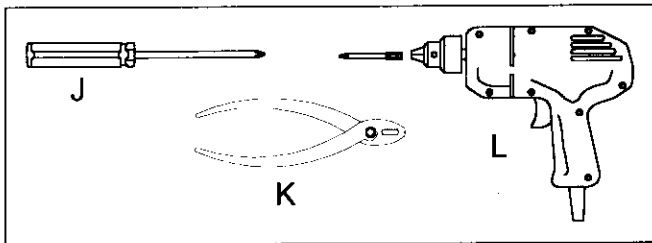

TOOLS REQUIRED

- 1 J Phillips Screwdriver
- 1 K Pliers

OPTIONAL

- 1 L Electric Drill
- 1 L Phillips Tip

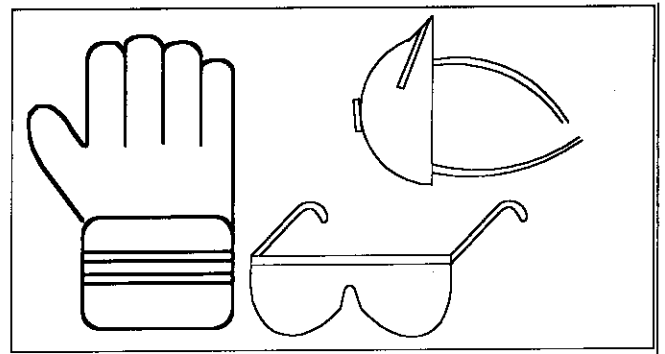

SAFETY GEAR

- 1 Gloves
- 1 Safety eyewear
- 1 Respirator

(Optional electric or battery drill with Phillips tip will speed-up the assembly process considerably)

PARTS IDENTIFICATION

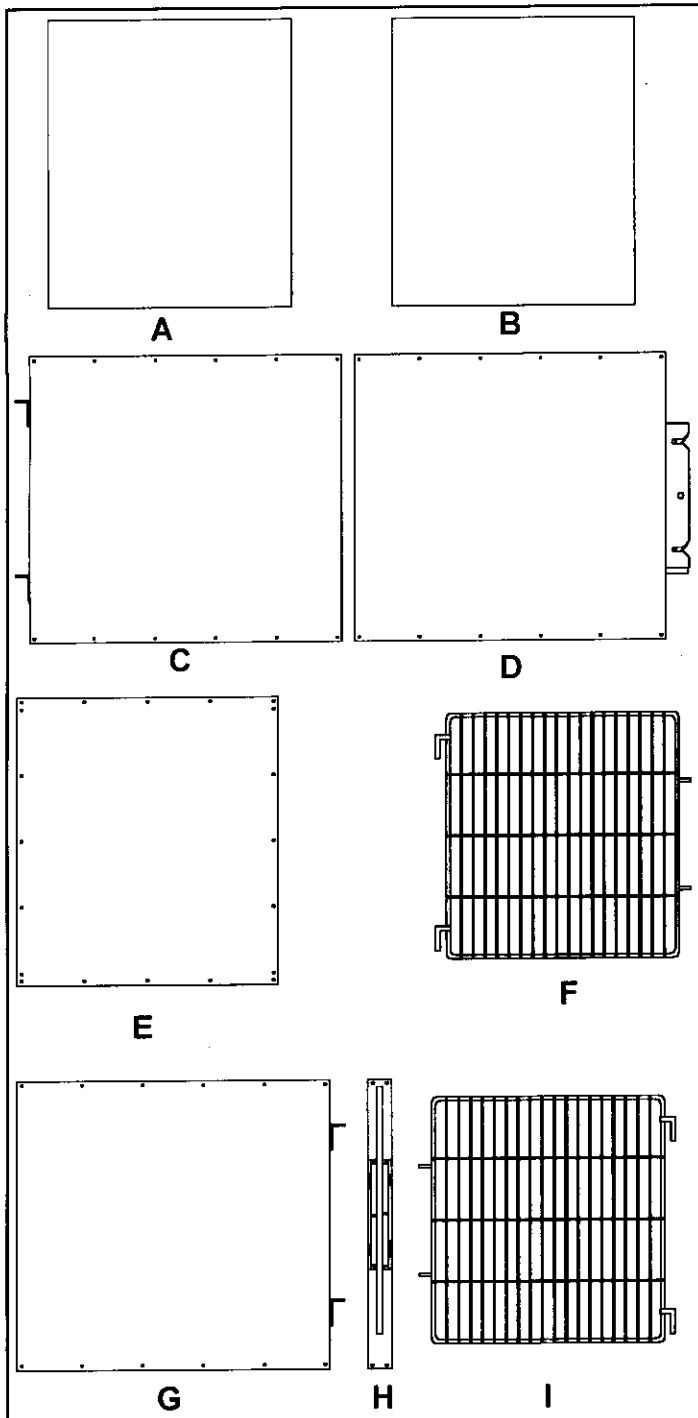
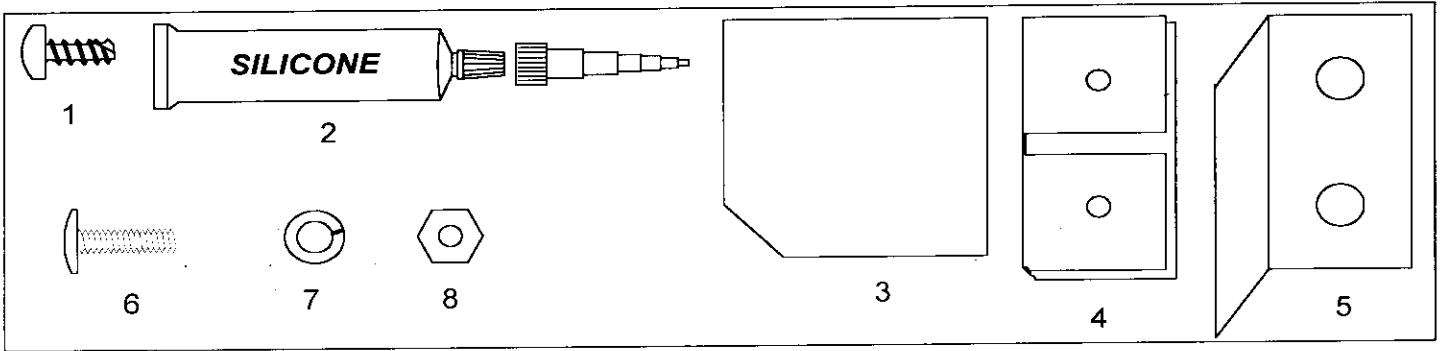

Item	Description	Qty
1	# 8 Type 25 screw	50
2	8 Oz clear silicone	1
3	Plastic trowel	1
4	Clip bracket	3
5	End L-bracket	1
6	8-32 X 1/2 Phillip screw	2
7	# 10 Lock washer	2
8	8-32 Hex nut	2
A	Bottom panel	1
B	Top panel	1
C	Left panel	1
D*	Right panel	1
E	Back panel	1
F	Right door	1

Additional parts for F630

G*	Right panel	1
H	Center bar w/latches	1
I	Left door	1
6	8-32 X 1/2 Phillip screw	4
7	# 10 Lock washer	4
8	8-32 Hex nut	4

* F630 "G" panel will replace "D" panel.

Items 1, 3, 4, 5, 6, 7, 8 actual size
 Items 2, A, B, C, D, E, F, G, H, I not to scale

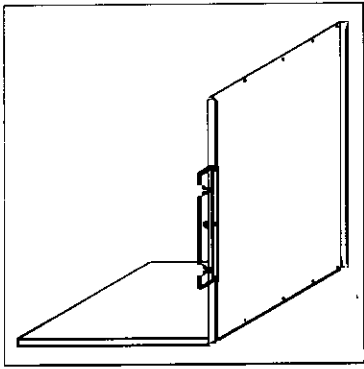

Illustration (a)

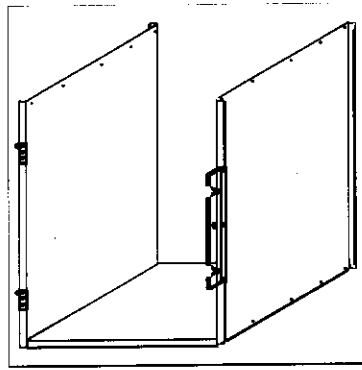

Illustration (b)

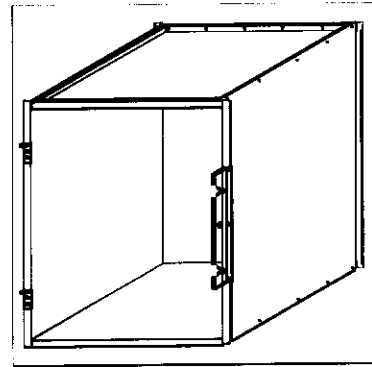

Illustration (c)

Prior to assembly, identify Front of 'Bottom Panel A' and 'Top Panel B'. Front of Panels have no holes.

Step 1. Use a flat, level surface to assemble cages. Line up 'Bottom Panel A' (Front facing toward you) and 'Right Panel D*' (Latches facing front) as shown in illustration (a) with flat surface of panels to the inside. Use Item (1) # 8 type 25 screw. Drive screw into holes with tool (J) Phillips screwdriver or optional tool (L) electric drill.

*** F630 (ED630/ED26043) 'Right Panel G' will replace 'Right Panel D'**

Step 2. Line up 'Left Panel C' and 'Bottom Panel A' as shown in illustration (b) with flat surface of panel to the inside and hinges to the same end as latch. Use Item (1) # 8 type 25 screw and attach side panel as in step 1.

Step 3. Line up 'Top Panel B' with panels C and D as shown in illustration (c) with holes of 'Top Panel B' to opposite side of latch and hinge with flat surface to the inside. Use Item (1) # 8 type 25 screw and attach panel as in step 1 and 2.

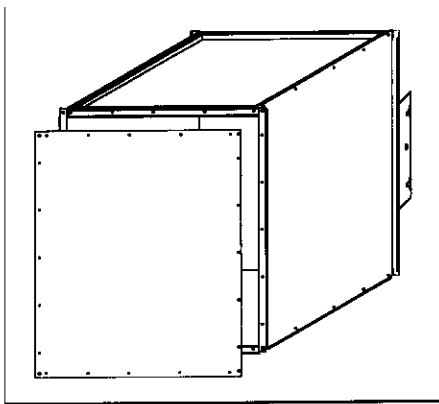

Illustration (d)

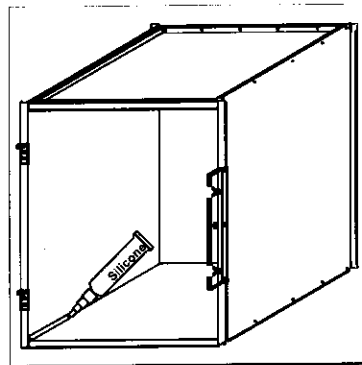

Illustration (e)

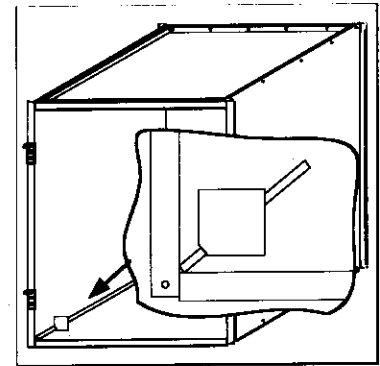
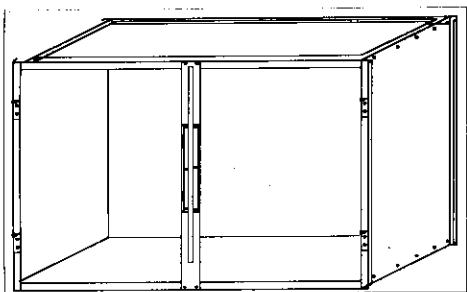

Illustration (f)

Step 4. Line up 'Back Panel E' as shown in illustration (d). Use Item (1) # 8 type 25 screw and attach panel as in steps 1,2, and 3. Note - do not screw corners until ready to assemble rows of cage banks.

Step 5. Wear respirator and safety eyewear for steps 5 and 6. Clean all panel joints to apply silicone - Item (2) 8 Oz clear silicone. Puncture metal seal in tip. Attach nozzle to silicone tube and cut the end to the third mark. Apply a 1/4" seal along all panel seams as shown in illustration (e).

Step 6. Use Item (3) plastic trowel to spread silicone as shown in illustration (f). Let dry for 30-45 minutes. Protect from moisture for 24 hours for proper cure. (F630 (ED630/ED26043) skip Step 6 and go to Step 6A)



F630 (ED630/ED26043) only

Step 6A. Attach 'Center bar w/latches (H)' to A and B panels using Item (6) 8-32 x 1/2 Phillips screw, Item (7) # 10 lock washer, and Item (8) 8-32 hex nut. See illustration (g). Drive screw Item (8) from the outside. Tighten the two nuts with washers securely using pliers Item (K) and screwdriver Item (J).

Illustration (g)

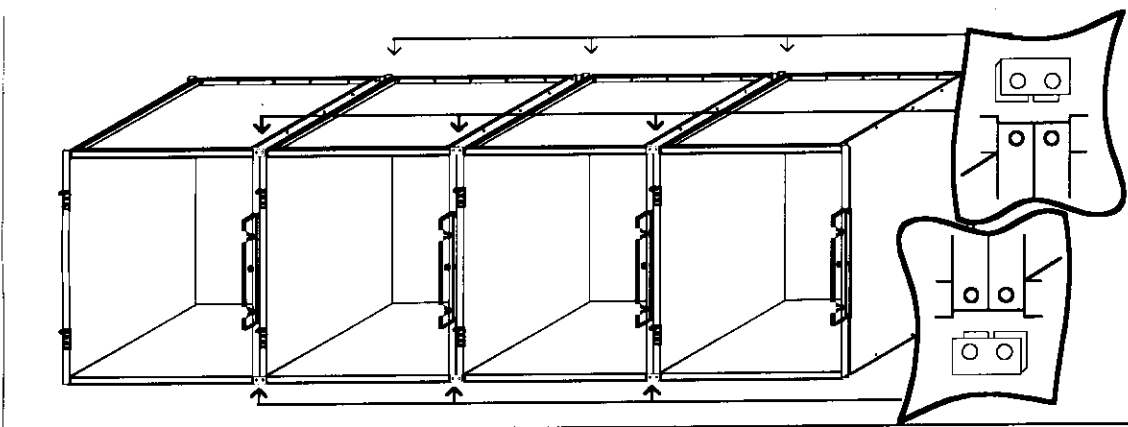
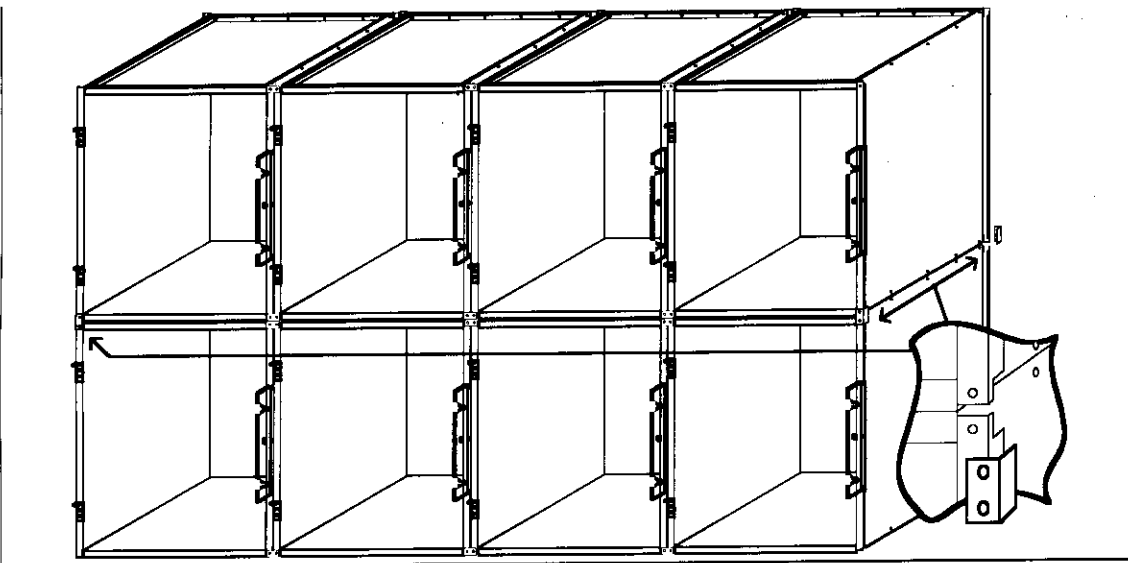

Illustration (h)

CAGE BANK ASSEMBLY

Step 7. Attach 'Clip bracket (4)' to bottom front and back of first cage using Item (1) # 8 type 25 screw. See illustration (h). Slide second cage over clip brackets and attach with Item (1) screw. Attach 'Clip bracket (4)' to top front and back of the two cages. See illustration (h). Repeat procedure for more cages, leaving the last cage without clip brackets.



Step 8. If more than one row, attach bottom row to top row with the 'End L-bracket - Item (5)'. See illustration (i).

Item (6), (7) and (8):

Drive Item (6) screw from the outside and Items (7) and (8) from the inside. Tighten the two nuts with washers securely using Item (K) pliers and Item (J) screwdriver.

Illustration (i)

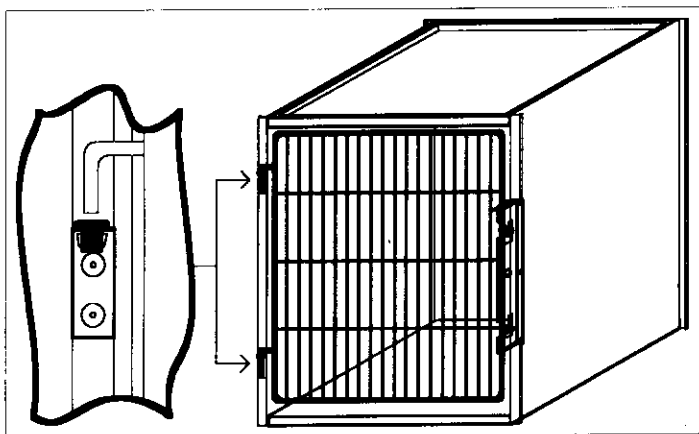

Step 9. Mount 'Right door (F)' to cage.

Note - F630 (ED630/ED26043) use Item (F) and Item (I)

See illustration (j). Use lubricant (WD-40 Light oil or similar lubricant) to make the door pin slide into the hinge.

Illustration (j)

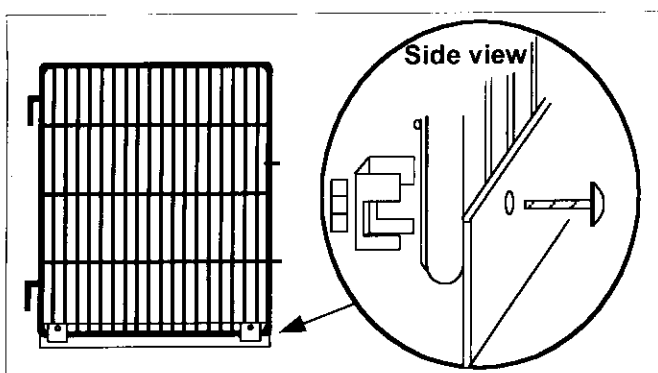

Step 10. Mount door bottom bracket (if floor grill and waste tray are used skip this last step and simply slide floor grill and waste tray into the cage). Mount bottom bracket from inside of door. Attach to door with clip holder from outside using Items (6) and (8). See illustration (k).

Now you have completed the assembly. Enjoy your new cage(s).

Illustration (k)

If you have any questions or need additional information please contact our Customer Service Department at 1-800-25EDEMCO (253-3362).

MAINTENANCE

Your new cages require minimum maintenance. The following steps are necessary to ensure good appearance and durability.

1. Remove animal waste daily.
2. Clean cages periodically.
3. Use a high velocity dryer to dry cage and remove moisture from gaskets, hardware, and doors.
4. Check silicone seals periodically and replace when necessary.

PARTS ILLUSTRATION / REPLACEMENT PARTS LIST

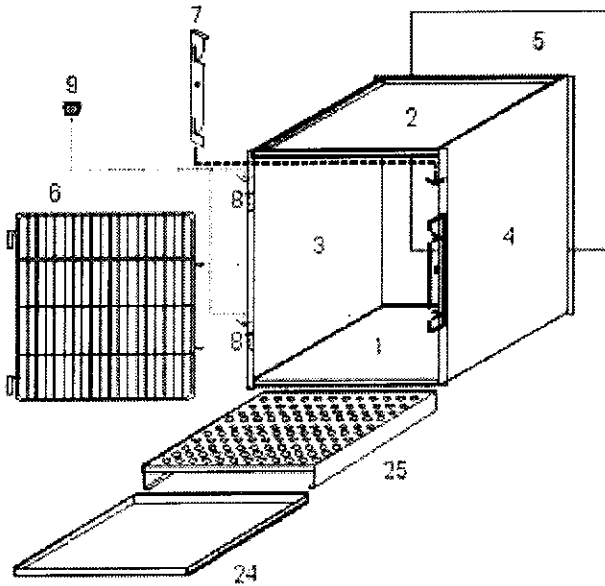

ED605/ED26017		F605
ITEM#	PART#	DESCRIPTION
1		A PANEL/605
2		B PANEL/605
3		C PANEL/605
4		D PANEL/605
5		E PANEL/605
6		DOOR/605
23		DOOR BOTTOM BRACKET/605
24		WASTE TRAY/605
25		FLOOR GRILL/605

ED607/ED26021		F607
ITEM#	PART#	DESCRIPTION
1		A PANEL/607
2		B PANEL/607
3		C PANEL/607
4		D PANEL/607
5		E PANEL/607
6		DOOR/607
23		DOOR BOTTOM BRACKET/607
24		WASTE TRAY/607
25		FLOOR GRILL/607

ED607/ED26022		F610
ITEM#	PART#	DESCRIPTION
1		A PANEL/610
2		B PANEL/610
3		C PANEL/610
4		D PANEL/610
5		E PANEL/610
6		DOOR/610
23		DOOR BOTTOM BRACKET/610
24		WASTE TRAY/610
25		FLOOR GRILL/610

ED620/ED26029		F620
ITEM#	PART#	DESCRIPTION
1		A PANEL/620
2		B PANEL/620
3		C PANEL/620
4		D PANEL/620
5		E PANEL/620
6		DOOR /620
23		DOOR BOTTOM BRACKET/620
24		WASTE TRAY/620
25		FLOOR GRILL/620

ED630/ED26043		F630
ITEM#	PART#	DESCRIPTION
1		A PANEL/630
2		B PANEL/630
3		C PANEL/630
10		D PANEL/630
5		E PANEL/630
6		RIGHT DOOR/630
12		LEFT DOOR/630
11		CENTER BARS/630
24		WASTE TRAY/630
25		FLOOR GRILL/630

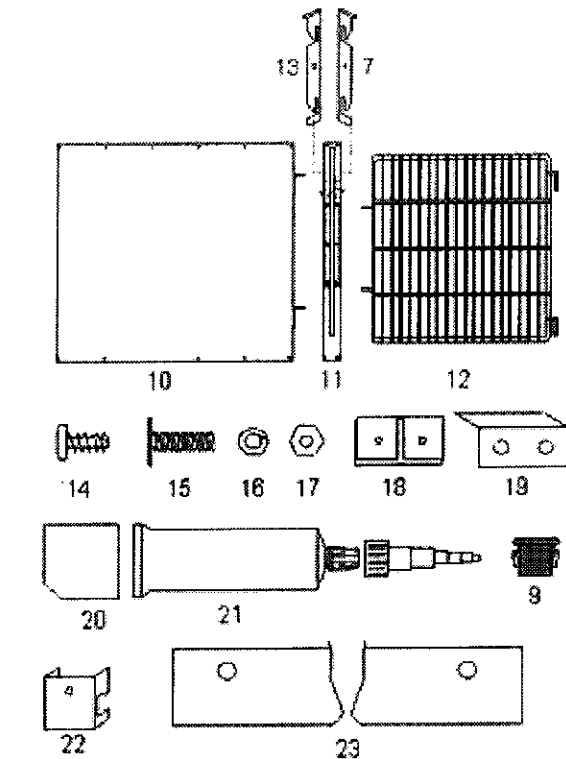

GENERIC HARDWARE

ITEM#	PART#	DESCRIPTION
7		RIGHT INNER LATCH
8		HINGE
9		PLASTIC BUSHING
13		LEFT INNER LATCH
14		# 8 TYPE 25 SCREW
15		8-32 X 1/2 PIN
16		# 10 LOCK WASHER
17		8-32 HEX NUT
18		CLIP BRACKET
19		CORNER L-BRACKET
20		PLASTIC TROWEL
21		8 OZ CLEAR SILICONE
22		DOOR BRACKET HOLDER
23		

ALL CAGES HAVE RIGHT INNER LATCHES. THE 630 CAGES HAVE RIGHT AND LEFT INNER LATCHES

