

Guardian Gear® Sprinter EXT Instructions

Parts List:

- A. Stroller Frame & Body (1)
- B. Back Wheels (2)
- C. Locking Pins (2)
- D. Axle (1)
- E. Washers (4)
- F. Rear Brakes (2)
- G. Cup Holder (1)
- H. Bottom Storage Basket (1)

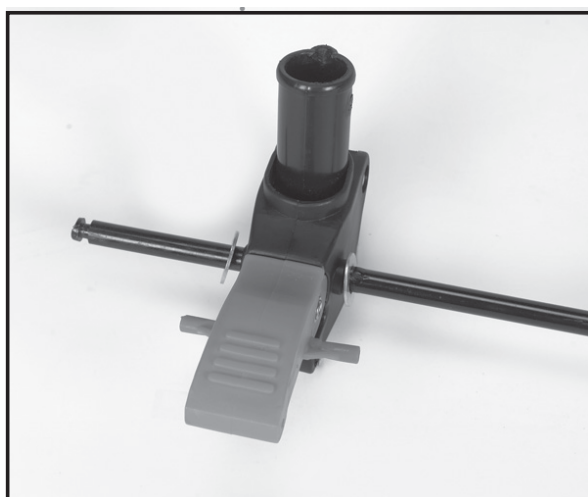
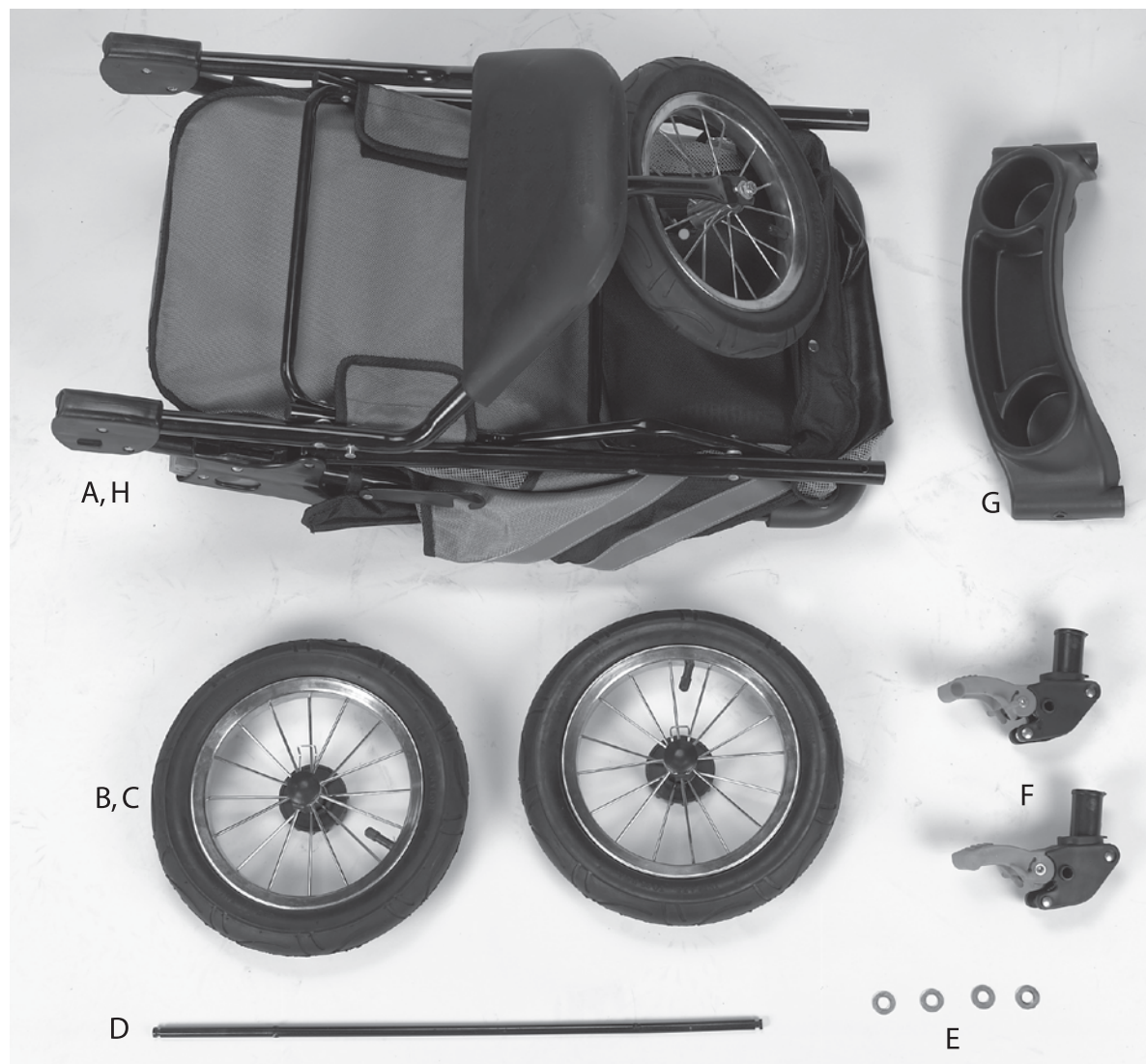

1. Remove the Stroller Frame & Body (A) from the box and unfold.
2. Slot two Washers (E) onto Axle (D). Slide Rear Brakes (F) onto Axle. Then slot the remaining two Washers (E) onto Axle as shown.

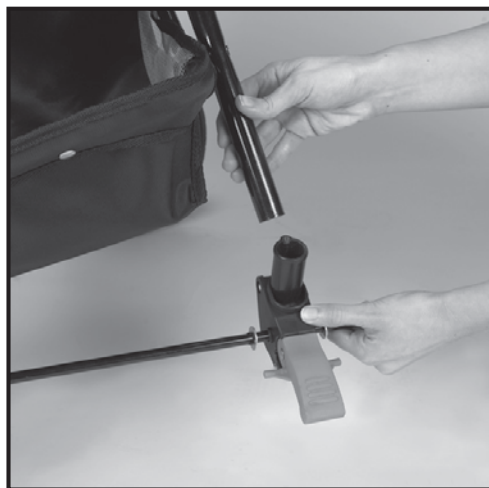

3. Attach the Axle (D) to the rear legs of the Stroller Frame by pushing the frame legs into the Rear Brakes (F) until the metal tabs click in place.



4. Slide the two Back Wheels (B) onto Axle (D).



5. Push the Locking Pins (C) through the black caps on front of Wheels to secure Wheels to Axle.



6. Hook the loops on the Bottom Storage Basket (H) over the frame to secure Basket in place.



7. Attach the Velcro® straps on the sides of the Stroller Body to the belly bar of the Frame.



8. Attach the Cupholder (G) to the top of the Frame near the handle and snap into place.

