

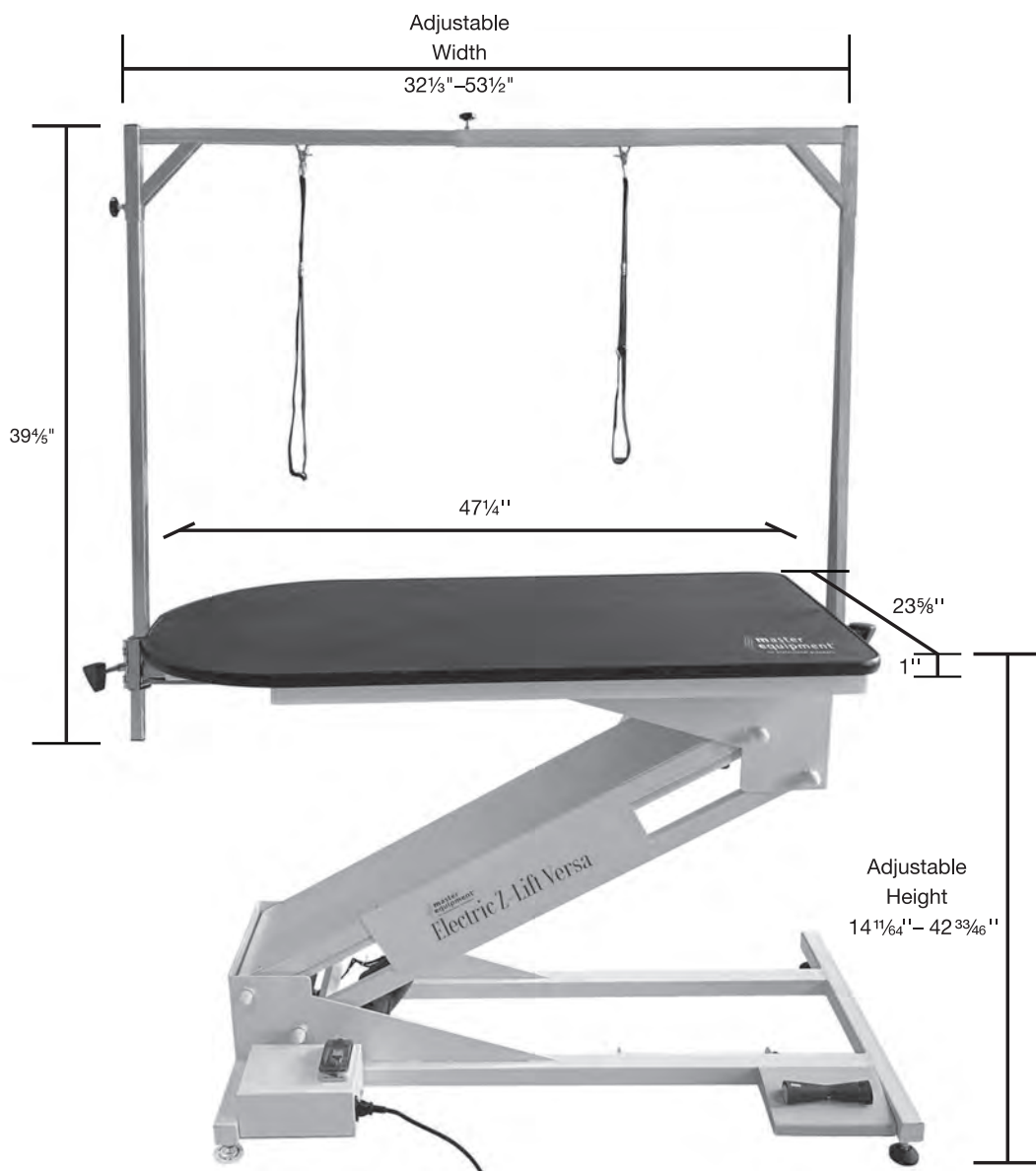

TP8989 47 95 Master Equipment® Z Lift Versa Electric Table



Accessories Included:

- Overhead grooming arm
- Square Tubing: 4/5"
- Height: 39 1/4"
- Width: 32 1/3" - 53 1/2"
- Grooming arm
- Adjustable levelers
- Grounding Foot
- Adjustable Leveler

Specifications:

- Color: White
- Dimension:
L: 47 1/4" x W: 23 5/8" x
H: 14 1/4" - 42 33/64"
- Package:
L: 48 2/5" x W: 24 4/5" x
H: 15 3/4"
- Net Weight: 136.7 lbs
- Gross Weight: 143.3 lbs
- Loading Capacity:
350 lbs

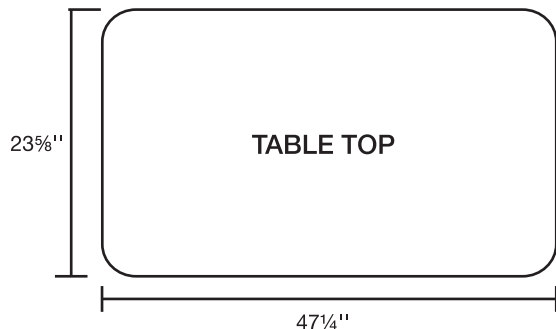

Grounding Foot Adjustable Leveler is for electrical safety in the event of a power surge. Please place on the table foot located under the Power Box.

Voltage & Power:

- Rated Voltage:
AC 110V-120V